

**DELTA PT®****BOSS
GUIDE**

NO		
1	PC	M 1.4
2	PC	M 1.6
3	PC	M 1.8

SCREW	DELTA PT® M 1.4
	P C

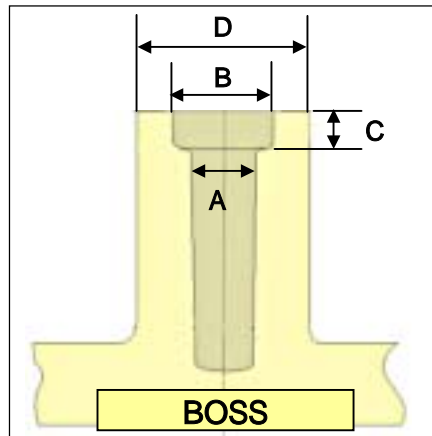
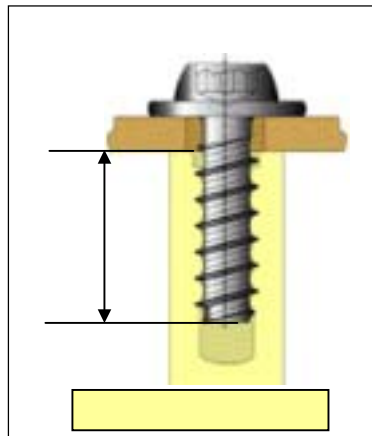

A	Hole	1.00	+0 -0.05
B	Hole	1.50	
C	Hole	0.30	
D	Boss	Min 2.8	
	Hole	REF(1 °)	
	TORQUE	0.8 kgfcm	
	()	Min 3.0 mm	

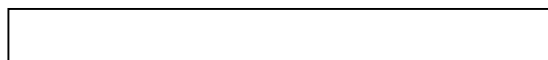

		가	TORQUE		Pull Out		Torque						
			kgfcm		Kg		1	2	3	4	5		
M1.4	1.5	가	0.30	Boss	2.5	Screw	가						
	2.0		0.80		22.5		가						
	2.5	TORQUE	1.10		30.0		1.0	0.75	0.75	0.60	0.60	0.55	73%
	3.0	가	1.60		35.0	Boss	1.0	1.00	1.00	0.90	0.90	0.95	95%
	3.5		1.60		35.0		1.0	1.05	1.00	1.00	1.00	1.00	95%
	4.0		1.70		37.5		1.0	0.95	0.95	1.00	0.90	0.90	95%

SCREW	DELTA PT® M 1.6
	P C

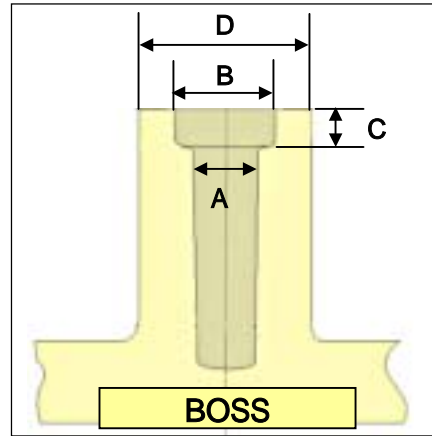
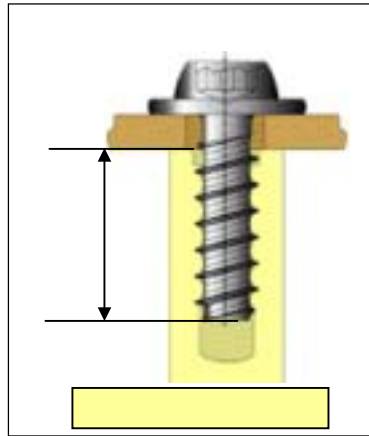

A	Hole	1.15	+0 -0.05
B	Hole	1.70	
C	Hole	0.50	
D	Boss	Min 3.00	
	Hole	REF(1 °)	
	TORQUE	1.0 kgfcm	
	()	Min 3.0 mm	

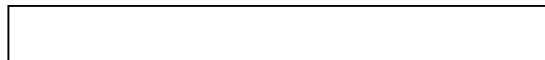

		가	TORQUE		Pull Out		Torque						
			kgfcm		Kg		1	2	3	4	5		
M1.6	1.5	가	0.45	Boss	5.0	Screw	가						
	2.0		1.30		15.0		가						
	2.5	TORQUE	1.60		32.5		1.4	1.15	0.90	0.90	0.85	0.80	70%
	3.0	가	2.20		35.0	Boss	1.4	1.30	1.10	1.15	1.15	1.00	77%
	3.5		2.80		35.0		1.4	1.60	1.60	1.55	1.50	1.45	91%
	4.0		2.80		35.0		1.4	1.30	1.25	1.20	1.15	1.05	81%

SCREW	DELTA PT® M 1.8
	P C

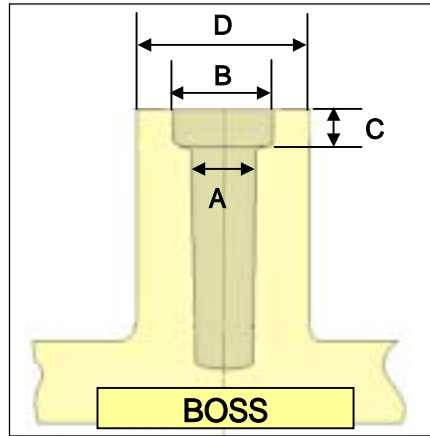
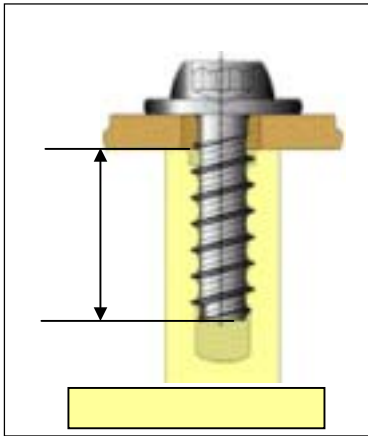

A	Hole	1.30	+0 -0.05
B	Hole	1.90	
C	Hole	0.60	
D	Boss	Min 3.20	
	Hole	REF(1 °)	
	TORQUE	1.2 kgfcm	
	()	Min 2.0 mm	

--

		가	TORQUE		Pull Out		Torque						
			kgfcm		Kg			1	2	3	4	5	
M1.8	1.5	가	0.70	Boss	10.0	Screw	가						
	2.0		2.20		32.5		가						
	2.5	가	3.40		35.0	Boss	1.6	1.20	1.05	1.00	1.00	1.05	88%
	3.0		3.50		35.0		1.6	1.40	1.50	1.45	1.50	1.50	107%
	3.5		3.60		35.0		1.6	1.80	1.75	1.70	1.80	1.80	100%
	4.0		3.60		35.0		1.6	1.65	1.75	1.70	1.75	1.60	97%